

8 x 8 Audio Matrix with Local Control

# PX-8000

(With RM-8000/LM-8000)





## OVERVIEW

The PX-8000 is an easy-to-operate 8 × 8 matrix mixer/controller that is usable with or without remote modules. The PX-8000 and related components provide the latest technology combined with ease of operation to create a system that offers enormous capability and flexibility. Local audio sources may be sent to any combination of up to eight remote zones and can do so with remote control unit. This type of flexibility makes this product ideal for any type of multi-zone system, including hotels, airports, casinos, hospitals, conference centers, and restaurants. The remote devices ensure that the right amount of control is located in the correct locations throughout a facility. The unit features local and remote paging capabilities with priority control. Each of the eight output zones is capable of being controlled by a remote station.

A monitor speaker is built in for local signal monitoring at the controller. Phantom power is provided for use with condenser microphones. The unit has both bass and treble tone controls per channel. The PX-8000 is powered by 100-120 VAC or 220-240 VAC 50/60Hz (depending on country requirements). The unit is packaged in a 5.25" high (3RU) rack-mount enclosure.

## Features

- 8 BGM x 8 ZONE MATRIX
- 8 local control
- 4 remote microphone
- Trigger contact(8)for remote message playback
- Output expansion ports(MASTER/SLAVE)terminal (Link multiple PX8000)
- PAGING microphone input, w / phantom
- PAGING microphone, voice control function
- 3 step CHIME
- DRP recording and playback(60 seconds)
- ZONE tone control(Base/Treble)
- Input / output volume control
- BGM audio confidence monitoring through built-in speaker
- 7-Segment alpha-numeric display and LED meters BGM channel display
- LED output level meter
- Local control functions (When LM control is deselected)
- BGM input signal LED(-30 dB)
- Priority broadcasting : PAGING > DRP > RM > LM > BGM
- CAT-5 cable with easy installation(300 m)long-distance
- 8-channel balanced output terminals



**8 BGM x 8 ZONE MATRIX**

Any combination of 8 BGM sources can be broadcasted to any combination of 8 outputs. Outputs can easily be increased by multiples of 8 simply by linking multiple PX-8000 together.



**LOCAL CONTROL**

Local control is possible using the wall mounted remote control with selection of local background music source in a remote zone as well as control of its volume. Local input allows for line level signal input as well as a microphone.



**PAGING**

Multi-zone paging is possible using the Remote Paging microphones. Up to 4 RM mics can be connected to the PX8000



**PRE-RECORDER MESSAGE PLAYBACK**

Trigger contact(8) for remote message playback

**Front / Rear Panel**

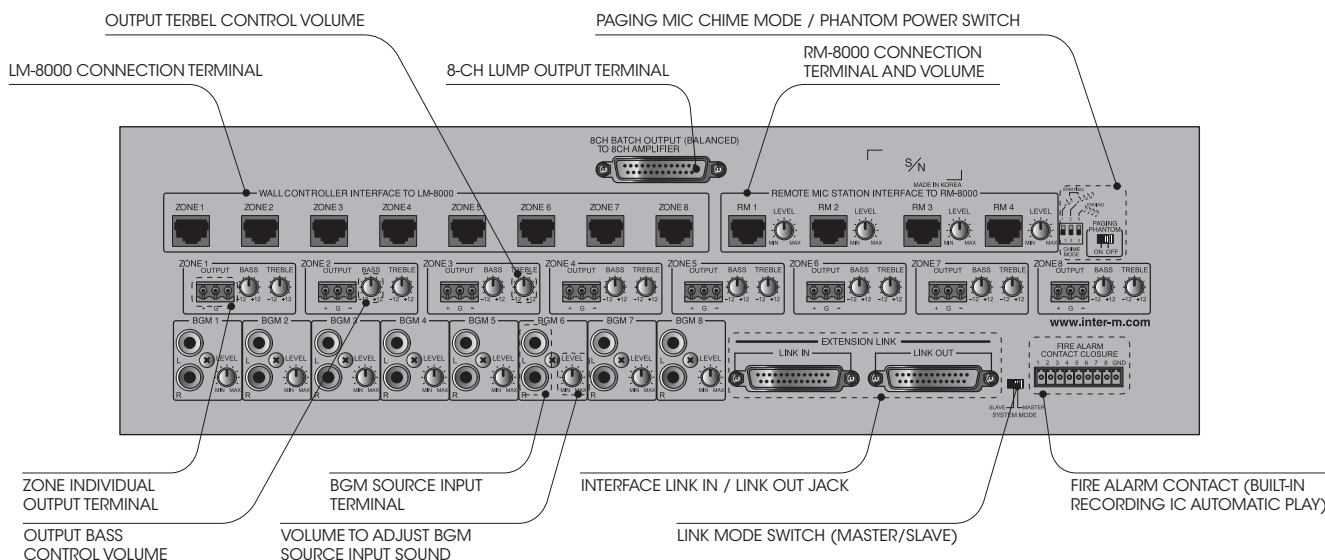
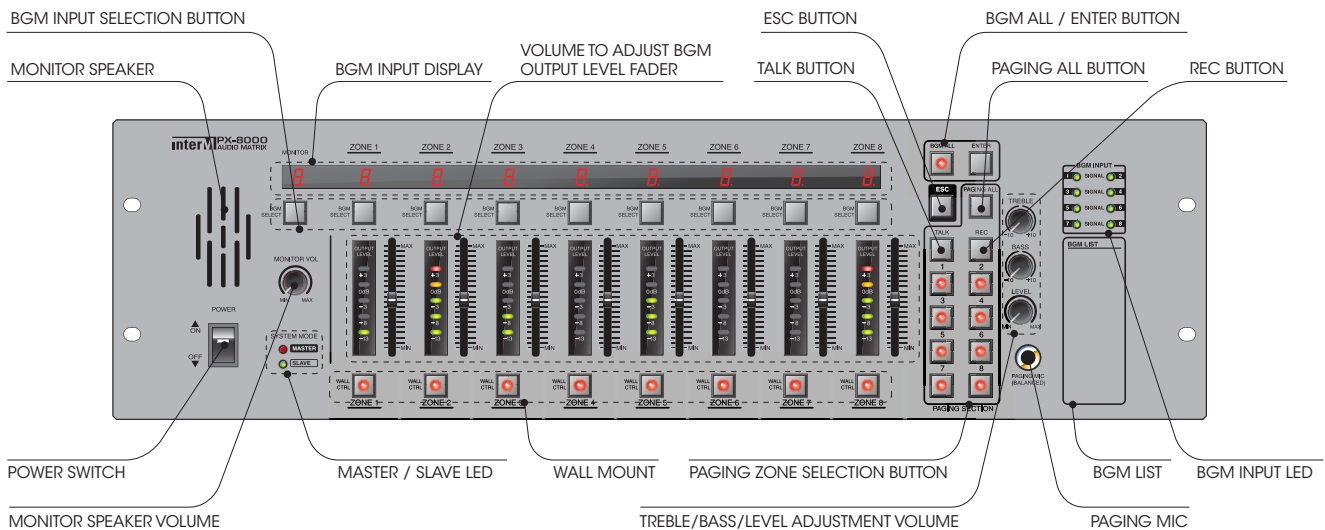

# Connection

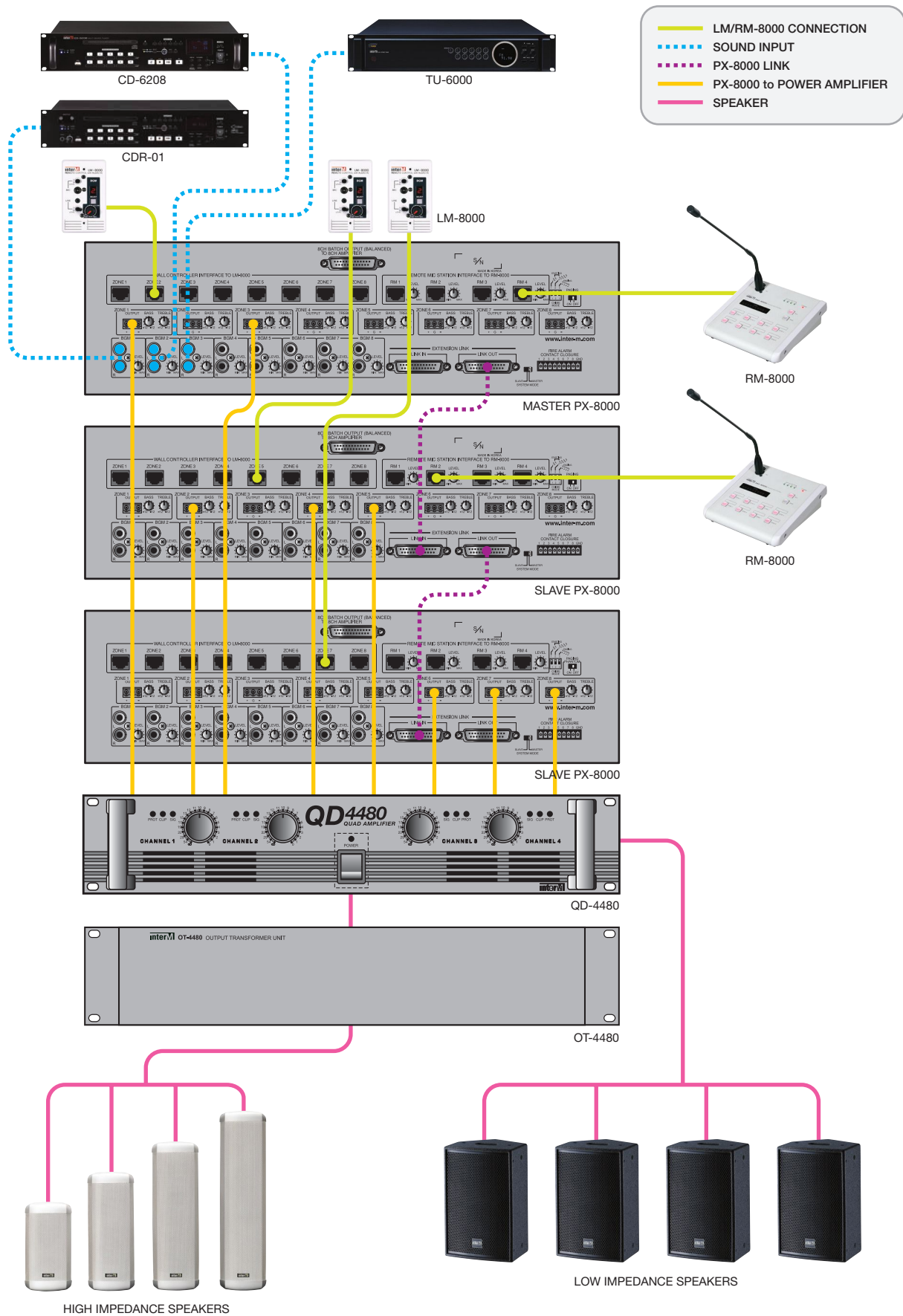

**LM-8000** Remote Control Audio In

**RM-8000** Remote Mic Station



**Features**

- Easy integration wiring(power, audio, communications)
- local microphone input, line input and volume control
- BGM channel selection and volume adjustment
- BGM channel display
- Easy Wall installation in a standard NEMA electrical outlet box

**Features**

- Remote Microphone
- Easy cat5e wiring(power, audio, communications)
- Broadcast Microphone primary supply
- Microphone Level LED output
- Selectable pre announce chime
- 8 Individual or all Zone Paging
- Status display
- Ergonomic table type



## Application 1 - Restaurant

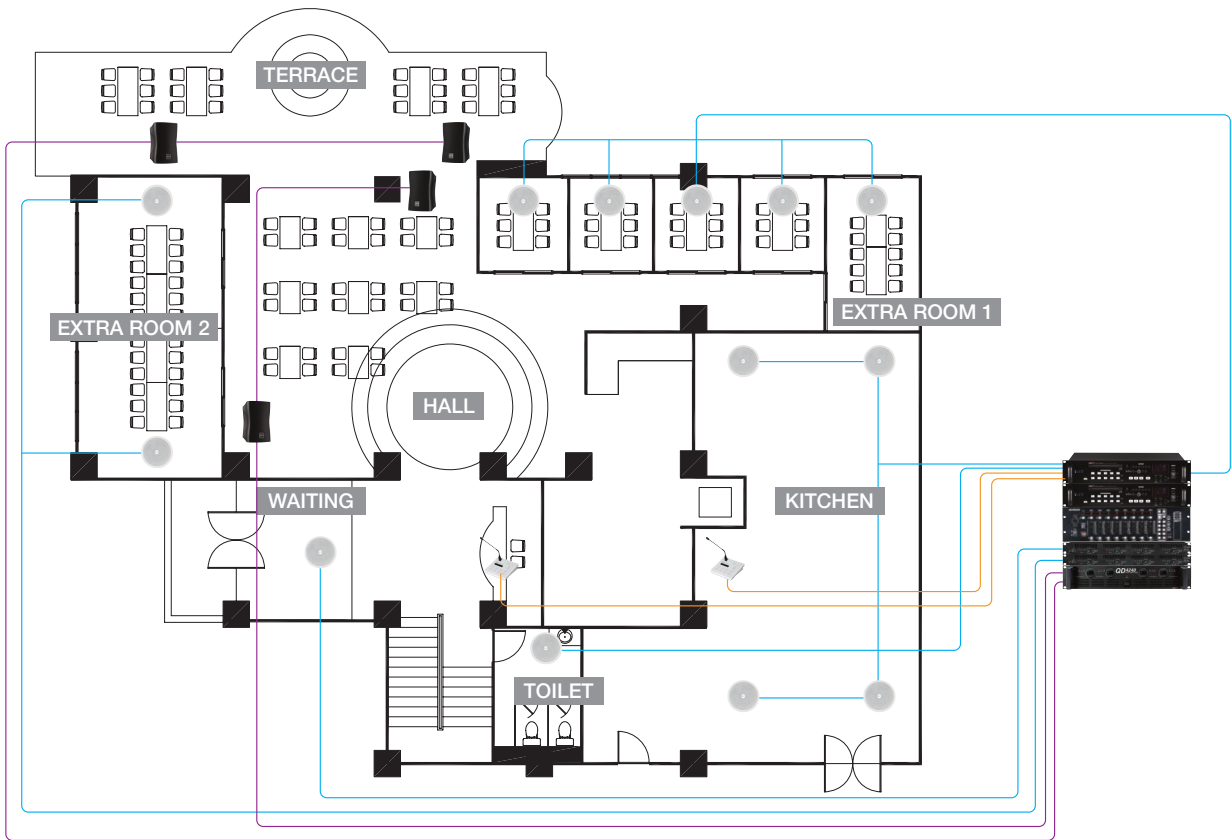

## Application 2 - Training Facility

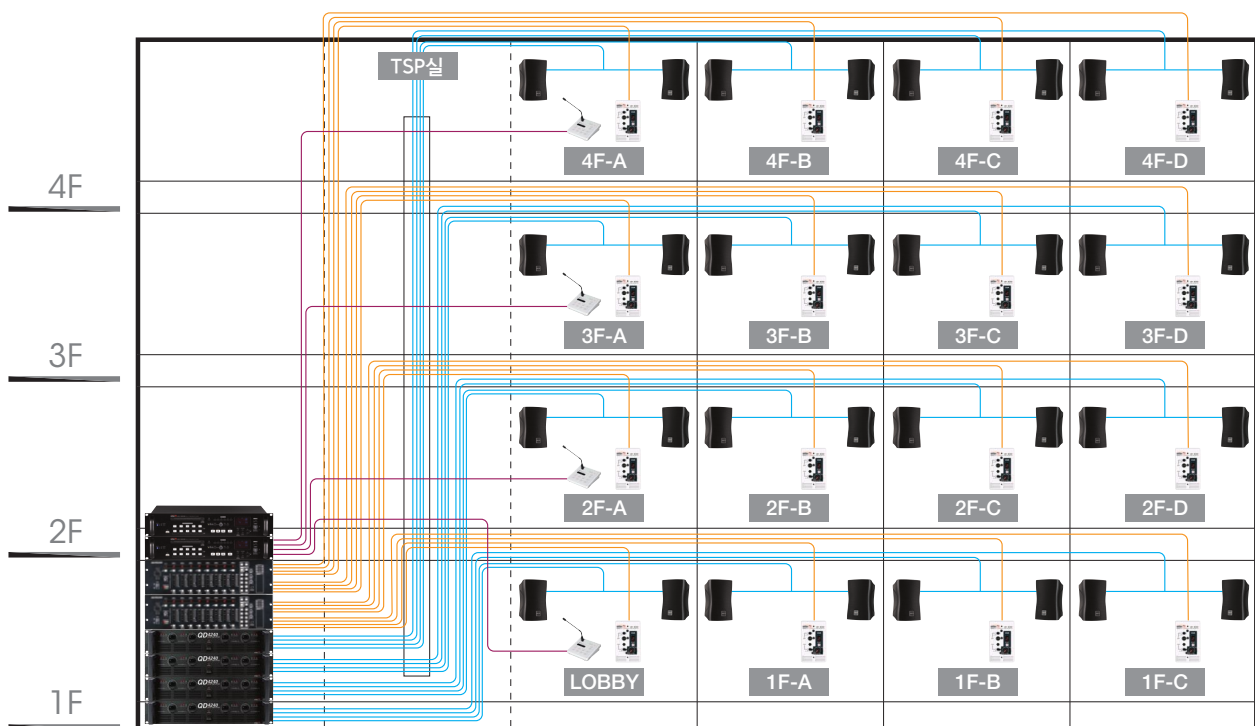

# Technical Data

Model	<b>PX-8000</b> 	<b>RM-8000</b> 	<b>LM-8000</b> 
Audio Output	0 dB(Balanced)	0 dB(Balanced)	0 dB(Balanced)
Audio Input - Paging & RM MIC & LM MIC	-50 dB(Balanced)	-50 dB(Balanced)	-50 dB(Balanced)
Audio Input - BGM(Main & Local)	-10 dB (Balanced)	-10 dB (Balanced)	-10 dB (Balanced)
Tone Control(100 Hz & 10 kHz) - Paging MIC	±10 dB	±10 dB	±10 dB
Tone Control(100 Hz & 10 kHz) - Audio Output	±12 dB	±12 dB	±12 dB
Frequency Response - BGM(60 Hz~15 kHz)	±3 dB	±3 dB	±3 dB
Frequency Response - MIC(100 Hz~10 kHz)	±3 dB	±3 dB	±3 dB
S/N - BGM	Better than 75 dB	Better than 75 dB	Better than 75 dB
S/N - MIC	Better than 65 dB	Better than 65 dB	Better than 65 dB
T.H.D. - BGM	Less than 0.05 %	Less than 0.05 %	Less than 0.05 %
T.H.D. - MIC	Less than 0.05 %	Less than 0.05 %	Less than 0.05 %
Priority Control	Paging MIC > DRP > RM1 > RM2 > RM3 > RM4 > LM-8000 > Main BGM		
Phantom Power	DC 24 V	DC 24 V	DC 24 V
Serial Interface(RS-422) - Communication Speed	9600 bps	9600 bps	9600 bps
Serial Interface(RS-422) - Communication Distance	Maximum 300 m(UTP CAT5)	Maximum 300 m(UTP CAT5)	Maximum 300 m(UTP CAT5)
Operation Temperature	-10 °C ~ +40 °C	-10 °C ~ +40 °C	-10 °C ~ +40 °C
Power Source	100-120 VAC or 220-240 VAC; 50/60 Hz (Supplied AC mains transformer depends on country requirements)		
Power Consumption	60 W	-	-
Weight(SET)	7.5 kg/16 lbs	1.5 kg/3.2 lbs	130 g/0.28 lbs
Dimensions(SET)	482(W)×132(H) x 380(D) mm 19(W)×5.2(H)×15(D) in	200(W)×70(H)×206(D) mm 7.9(W)×2.8(H)×8.1(D) in	70(W)×114(H)×52(D) mm 2.8(W)×4.5(H)×2.0(D) in

\* Specifications and design are subject to change without notice.



**Inter-M Corp. (IMK)**

719, Dobong-ro, Dobong-gu, Seoul, Korea  
Overseas Sales Team

Tel\_ +82-2-2289-8141~7 Fax\_ +82-2-2289-8149 E-mail\_ overseas@inter-m.com

[www.inter-m.com](http://www.inter-m.com)

※ Design and specification are subject to be changed for the improvement of product quality without pre notice.

2015. 10. V3